

# ARMOIRE COULISSANTE COMPLÈTE 6 CORBEILLES

VIBO

**VIBO**  
Design your space

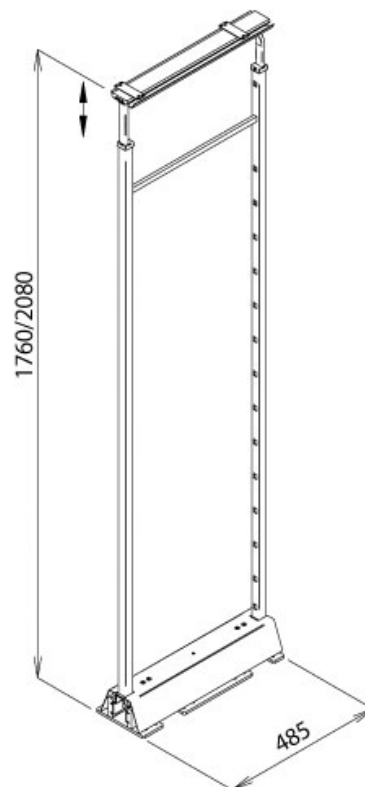

<https://www.socomenal.com/armoire-coulissante-vibo-6-corbeilles-p10595>



Tel : 03 88 78 96 96

Fax : 02 43 30 26 16

[www.socomenal.com](http://www.socomenal.com)

# ARMOIRE COULISSANTE COMPLÈTE 6 CORBEILLES

VIBO

**VIBO**  
Design your space

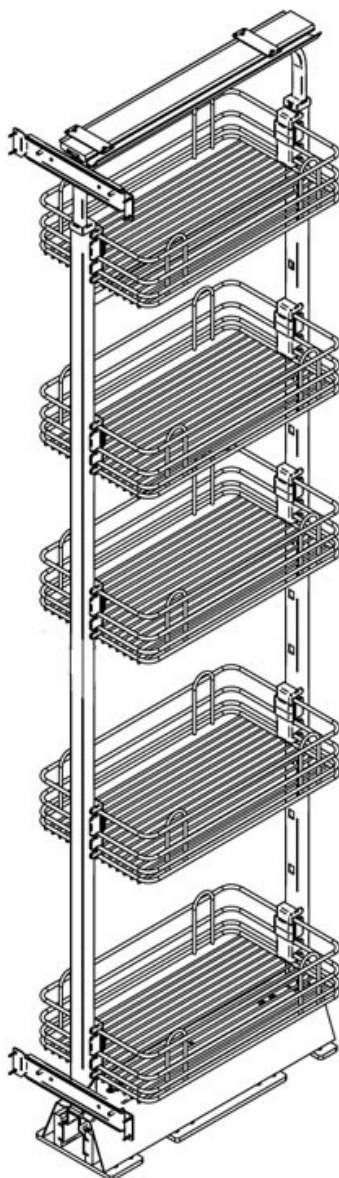

<https://www.socomenal.com/armoire-coulissante-vibo-6-corbeilles-p10595>



Tel : 03 88 78 96 96

Fax : 02 43 30 26 16

[www.socomenal.com](http://www.socomenal.com)